

MACURCO

GAS DETECTION



Parking Garage Guide

Building owners and facility managers want to provide safe and effective parking garages while minimizing the energy costs associated with heating, ventilation and air conditioning.

This application guide helps engineers, installers and integrators provide suitable gas detection systems for enclosed parking garages.



Made in the USA





1. Why install a gas detection system?
2. What standards are followed?
3. Carbon monoxide alarm levels and sequence of operation
4. Mechanical ventilation considerations
5. Equipment Selection and Location
6. On-board diagnostics
7. Output signals
8. Close out

1. Why install a gas detection system?

Safety

The solution to pollution is dilution. The solution to vehicle exhaust in parking garages is dilution with “fresh” air drawn in by fans, louvers and doors until reaching an acceptable gas concentration. Macurco gas detectors provide automatic exhaust fan control to help maintain acceptable levels of Carbon Monoxide (CO), Combustible Gases (EX) or Nitrogen Dioxide (NO₂) in parking garages. Consult local codes for the specific requirements.

Carbon monoxide (CO) is an odorless, colorless gas that is found in combustion fumes, such as those produced by cars and trucks and small gasoline engines. CO from these sources can build up in enclosed or semi-enclosed spaces and people in these spaces can be poisoned by breathing it. The most common symptoms of CO poisoning are headache, dizziness, weakness, nausea, vomiting, chest pain, and confusion. High levels of CO inhalation can cause loss of consciousness and death. www.cdc.gov

Nitrogen dioxide (NO₂) is a reddish-brown gas with a pungent, acrid odor and is one of a group of highly reactive gasses known as "oxides of nitrogen," or "nitrogen oxides (NOx)." NO₂ forms quickly from car, truck and bus emissions. Health effects associated with nitrogen dioxide exposure (NO₂) include eye, nose, and throat irritation. It may cause impaired lung function and increased respiratory infections in young children. Extremely high-dose exposure to NO₂ may result in pulmonary edema and diffuse lung injury. www.epa.gov

Gasoline is used as a fuel for engines in cars. It is colorless to pale brown or pink in color with a distinctive odor. Generally, the odor of gasoline provides adequate warning of hazardous concentrations. Gasoline is a volatile, flammable liquid. Its vapors may travel to a source of ignition and flash back. Gasoline vapors are heavier than air and may collect in low-lying areas. Typically, gasoline contains more than 150 chemicals, including small amounts of benzene, toluene, xylene, and sometimes lead. www.atsdr.cdc.gov

Savings

When people think about sustainability and saving energy, the temptation is to think first of inhabited spaces like offices and residences, but one of the most important areas is in reducing energy consumption in enclosed parking garages. Installing ventilation controllers based on gas concentrations can substantially reduce consumption of both electricity and natural gas and pay for itself in less than one year.





Natural gas consumption is required to heat parking garages in colder climates. If ventilating fans are running continuously, it is no surprise when heating costs are high. One effective solution is to control the operation of the ventilating fans based on the quality of the air inside the parking garage. A system which operated the fans only when carbon monoxide levels are elevated could reduce the fan operating time substantially. This will not only reduce electricity and natural gas consumption but could extend the life of the fans as well.

Silence

In residential facilities like condominiums with enclosed parking, the noise from exhaust fans can negatively impact tenant satisfaction. Noise pollution adversely affects the lives of millions of people. Studies have shown that there are direct links between noise and health. Problems related to noise include stress related illnesses, high blood pressure, speech interference, hearing loss, sleep disruption, and lost productivity.

The traditional definition of noise is “unwanted or disturbing sound”. Sound becomes unwanted when it either interferes with normal activities such as sleeping, conversation or disrupts or diminishes one’s quality of life. The fact that you can’t see, taste or smell it may help explain why it has not received as much attention as other types of pollution, such as air pollution, or water pollution. The air around us is constantly filled with sounds, yet most of us would probably not say we are surrounded by noise. For some, the persistent and escalating sources of sound can often be considered an annoyance which can have major consequences, primarily to one’s overall health. Noise Induced Hearing Loss (NIHL) is the most common and often discussed health effect, but research has shown that exposure to constant or high levels of noise can cause countless adverse health effects. epa.gov/air/noise

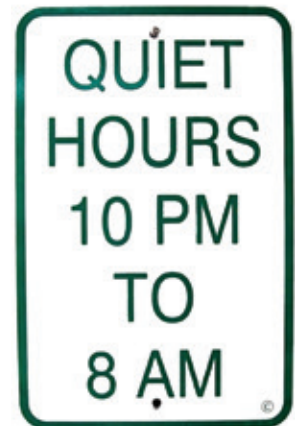

HVAC equipment for a building is one of the major sources of interior noise, and its effect on the acoustical environment is important. Further, noise from equipment located outdoors often propagates to the community. Therefore, mechanical equipment must be selected, and equipment spaces designed, with an emphasis on both the intended uses of the equipment and the goal of providing acceptable sound levels in occupied spaces of the building and in the surrounding community. Operation of HVAC equipment can also induce mechanical vibration that propagates into occupied spaces through structure-borne paths such as piping, ductwork, and mounts. Vibration can cause direct discomfort and also create secondary radiation of noise from vibrating walls, floors, piping, etc. <http://asp-hvac.com/wp-content/uploads/2011/10/ASHRAE-HANDBOOK-Sound-and-Vibration-Control.pdf>



2. What standards are followed?

Building Codes and Standards

Most states and local municipalities have building codes that recognize and recommend carbon monoxide detection and ventilation in enclosed parking garages. If local building code does not have any requirements for Carbon Monoxide or Combustible Gases and Nitrogen Dioxide detection in parking garages, it is still a good idea to educate the facility manager or design engineer that mitigation of these gases is a very important component of environmental health and safety in a parking garage. Consult local codes for the specific requirements.



Carbon Monoxide

OSHA - Occupational Safety and Health Administration

TWA: 50 ppm The maximum allowable concentration for a worker’s continuous exposure in any eight hour period

NIOSH - National Institute for Occupational Safety & Health

PEL– TWA: 35 ppm is the maximum allowable concentration for a worker to be exposed to in any eight hour period.

ACGIH - American Conference of Governmental Industrial Hygienists

TLV - TWA: 25 ppm is the maximum allowable concentration for a worker’s continuous exposure in any eight hour period.

Nitrogen Dioxide

Current **OSHA** PEL: 5 ppm (9 mg/m3) CEILING - 1989 OSHA PEL: 1 ppm (1.8 mg/m3) STEL - **NIOSH** REL: 1 ppm (1.8 mg/m3) STEL - 1993-1994 **ACGIH** TLV: 3 ppm (5.6 mg/m3) TWA, 5 ppm (9.4 mg/m3) STEL

International Mechanical Code - Section 403.5 Public garages

Mechanical ventilation systems for public garages arranged to operate automatically upon detection of concentration of carbon monoxide of 25 ppm by approved detection devices.

Uniform Building Code - section 705 - In all parking garages

Automatic CO sensing devices may be employed to modulate the ventilation system to maintain a maximum average of CO of 50 ppm during any eight-hour period, with maximum average concentration not greater than 200 ppm for a period not exceeding one hour. The uniform building code was replaced after 1997 by the International Building Code.

3. Gas Levels and Sequence Of Operation

Ventilation, Warning and Alarm

In parking garages vehicle traffic is part of everyday operations. Consequently exhaust gases containing carbon monoxide and nitrogen dioxide will be released into the air under normal conditions. A gas detection system in a parking garage should not go directly into alarm upon detection of carbon monoxide. This would be considered a nuisance. Instead when low levels of carbon monoxide or nitrogen dioxide are detected, then ventilation system should be engaged at the Rising Trip Point to draw in fresh air and reduce those gas concentrations to acceptable levels.

If the ventilation system is incapable of reducing the gas concentration and it continues to rise, the Warning signal may be activated indicating that there is an issue with the amount of exhaust accumulating in the space. If the ventilation system continues to be incapable of reducing the gas concentration and it continues to rise even higher, the Alarm signal may be activated indicating that there is a serious amount of exhaust accumulating in the space. The Warning and Alarm signal may be associated with buzzers, horns or strobes and activation of the fire or security system. Consult local codes for the specific requirements.



Rising Trip Point

Set at a low concentration usually 35ppm of CO and 2.5ppm of NO₂. Engages the ventilation system, drawing down the gas concentration until it reaches the Falling Trip Point

Falling Trip Point

Usually set to 15ppm for CO and 1.2ppm for NO₂. Disengages the ventilation system.

Multiple Fans

If the ventilation system is incapable of reducing the gas concentration and it continues to rise, that system remains operational and a 2nd ventilation system or fan is activated.

2nd Rising Trip Point

Set at a higher concentration usually 75ppm of CO and 2.8ppm for NO₂. Engages the 2nd ventilation system, drawing down the concentration until it reaches the 2nd Falling Trip Point.

2nd Falling Trip Point

Usually set to 35ppm of CO and 2.5ppm for NO₂, disengages the 2nd ventilation system. If the ventilation system is still incapable of reducing the gas concentration and it continues to rise, the ventilation systems remain operational and a warning condition activated.

Warning Level

Set at a higher concentration usually 100ppm of CO and 3ppm for NO₂. Engages the internal buzzer, horn or strobe drivers. Indication that there is a significant amount of exhaust accumulating in the space. If the ventilation system is still incapable of reducing the gas concentration and it continues to rise, the ventilation systems remain operational and an alarm condition activated.

Alarm Level

Set at an even higher concentration usually 200ppm of CO and 5ppm for NO₂. Engages the internal buzzer, horn or strobe drivers. Indication that there is a serious amount of vehicle exhaust accumulating in the space. If the ventilation system is still incapable of reducing the gas concentration and it continues to rise, the ventilation systems remain operational and an alarm condition activated. The Alarm signal may be associated with activation of a dialer or fire/security system.



Macurco Horn Strobe

4. Mechanical Ventilation Considerations

Defining the Ventilation System

Two main factors are required to size the ventilation system are the number of cars in operation and the CO and NO₂ emission quantities. Most codes simplify this estimate by requiring four to six air changes per hour for fully enclosed garages. Consult local codes for the specific requirements. The carbon monoxide monitoring system must be capable of activating both the exhaust fans and the air intake devices such as outside air louvers/dampers and make up air units. As per the Uniform Mechanical Code: Connecting offices (to parking garage), waiting rooms, ticket booths, etc., shall be supplied with conditioned air under positive pressure. The gas detection system activates the mechanical ventilation by using either dry contacts through magnetic starters, dry contacts through motor control center (MCC), dry contracts and/or analog outputs (4-20 mA) through the Building Automation System (BAS) or Analog outputs (4-20 mA) modulating the speed of the fans through variable frequency drives (VFD).

5. Equipment Selection and Location

Stand-alone Detectors

The Macurco 6-Series detectors provide CO, NO₂ and EX gas detection and automatic exhaust fan, louver or valve control for automotive maintenance facilities, enclosed parking garages, utility rooms, warehouses and other commercial applications. These single point, low voltage, dual relay gas detectors have selectable 4-20 mA output, buzzer and digital display options. The 6-Series meet the requirements of the Uniform Building Code and International Mechanical Code for enclosed garages and meet environmental safety standards for CO and NO₂ exposure. They can be used stand alone or with the Macurco DVP-120 Detection and Ventilation Control Panel.



The alarm relay contacts that can switch up to 0.5 A 120V, or 60VA and can be configured to normally open or normally closed. The alarm relay is activated if gas reaches or exceeds the alarm setting and will deactivate once the gas concentration drops below the alarm set point.

The dry contact, SPDT fan relay can switch up to 5.0 A up to 240 VAC and can be configured for latching or non-latching when activated (when the gas concentration exceeds fan relay set point). The Fan Relay will engage if the fan setting gas concentration is exceeded for longer than the Fan Relay Delay time. Unless it is configured for latching, the fan relay will disengage once the gas concentration has dropped below fan setting and the Fan Relay Run time has been exceeded. The fan relay can also be engaged in trouble fault condition.

The on-board relays can be used to control fans, valves, louvers, horn, strobes and other devices or report back to fire/security panels. The relays can be wired in parallel when multiple detectors are used. In this configuration either detector can report independently. If the relays are wired in series, both detector must report to cause activation.



Detection and Ventilation Control Panel

Typically for larger applications with multiple gases and sensing points. They are real-time reading with several programmable outputs. The Macurco DVP-120 Detection and Ventilation Panel, in conjunction with Macurco™ gas transducers, provides automatic controls to help maintain an acceptable environment in parking garages or other facilities. The DVP-120 system meet the requirements of the Uniform Building Code and International Mechanical Code for enclosed garages and meets environmental safety standards for CO and NO₂ exposure. The DVP-120 can control up to twelve gas sensors in any combination.

Configuration

The system configuration is entered by the user through the LCD display and keypad. The display provides the user with the system status, and the status of each configured sensor. All control functions of the DVP-120 may be accessed through the system display and keypad.

1. **Signal Configuration:** defines the output of the Alarm, Warning and Trouble Signals (Buzzer, Horn and Strobe) as On, Off, Intermittent, Continuous, etc.
2. **Relay, Horn and Strobe Configuration:** defines operation as Normally Off or On, Delay Time, Minimum Runtime – this applies to all three relays as well as the horn and strobe.
3. **System Configuration:** allows the installer to set the time of day, day of the week, load the default configuration, configure custom sensors and change the password.
4. **Sensor Configuration:** defines the Sensor type – CO, NO₂, EX, NH₃, H₂S, REF, CO₂, O₂, Custom (wildcard) or None and sets Alarm Level, Warning Level, and Sensor Range
5. **Zone Configuration:** defines Sensor Input & Relay/Alarm Output and sets up the sensor Groups (set of sensors of same type and output within the same zone) - Sensor type, Sensor Number, Rising Trip point and Falling Trip point, Timer option

System wiring includes: Main power connection for the DVP-120, the 4-20mA current loop and 24VDC power connections between the remote sensors and the DVP-120 (home run for each, via unshielded four conductor cable, AWG18 minimum), and Fan control connections and/or alarm connections from the DVP-120 to the building ventilation and automation systems. After wiring, simply plug the modular connectors into the matching connectors on the printed circuit board



Addressable Gas Detection and Control

The Macurco MRS-485 is a Modbus RS-485 adapter for use with Macurco 6-Series detectors. The Macurco MRS-485 adapter is an accessory used to convert the 4-20mA analog signal from Macurco 6-Series type detectors to a digital signal for use with multipoint addressable systems. The Macurco MRS-485 simply plugs into the back of the detector and a single screw fastens it in place. The MRS-485 accepts the 4-20mA output and is powered from the same connection as the detector. The MRS-485 has the ability to interface with Building Automation Systems, Control Panels or other Control Devices that accept Modbus communications.



The MRS-485 monitors sensor type, gas level and trouble status communications from any of the Macurco 6-Series detectors and communication is on a Modbus serial line. The Macurco MRS-485 uses a commercial type enclosure to protect and support the electronics, a tricolor LED to indicate power, test and communication status and an 8 bit dip switch to select address. The Macurco MRS-485 mounts behind the detector inside of a standard 4" x 4" electrical box and is held in place on the back of the 6-Series detector with a single screw. The Macurco MRS-485 output is connected via a four terminal screw type connector. The MRS-485 adapter is wired in the standard 2W-Modbus circuits definition with selectable built-in terminating resistors at the ends of the RS-485 bus. The power for the MRS-485 adapter is connected via a two terminal screw type connector, 12 to 24 VAC or VDC.



DVP-120M Modbus Enabled Detection and Ventilation Panel

The Macurco DVP-485 Adapter is an accessory used to allow the DVP-120 Detection and Ventilation Panel to receive Modbus communications from Macurco sensors via the MRS-485 adapter. The DVP-485 is an adapter, an additional printed circuit board, installed in the DVP-120 Detection and Ventilation Control Panel. The Modbus enabled control panel is the DVP-120M with up to 87 Modbus addressable sensors on three channels of 29 sensors per channel, plus the original 12 analog 4-20mA sensor channels. The DVP-485 increases the capacity of the DVP-120 from 12 detectors capable of covering 60,000sqft to 99 detectors which will cover up to 495,000sqft.

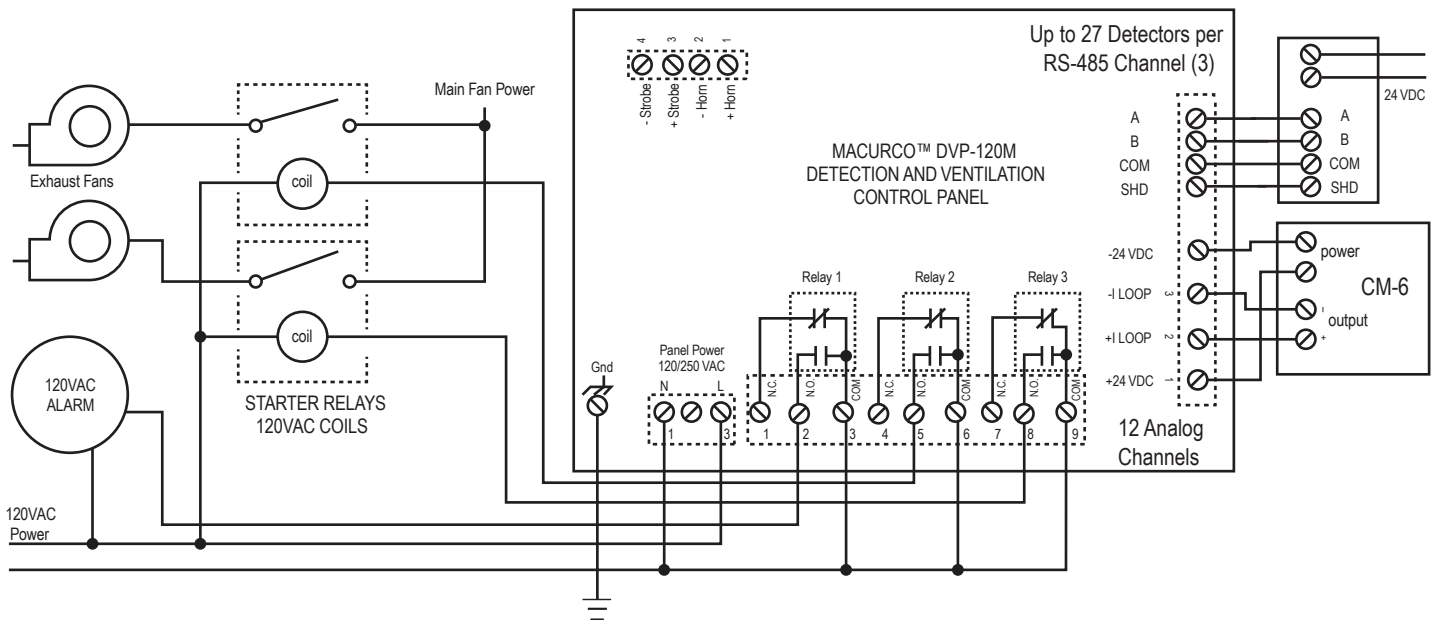

Equipment Location

Macurco CM-6 for Carbon Monoxide, TX-6-ND for Nitrogen Dioxide

These units typically cover about 5,000 sqft (465 square meters) in a parking garage or similar application. The radius of coverage is 40 ft (12.2 m) per detector.

- Mounted on a column the detector covers 5,000 sqft
- Mounted on a wall the detector covers 2,500 sqft
- Do not mount the in a corner.
- Do not mount where the normal ambient temperature is below 0°F or exceeds 125°F (-18°C to 52°C).
- Additional detectors may be needed near any areas where people work or where the air is stagnant.

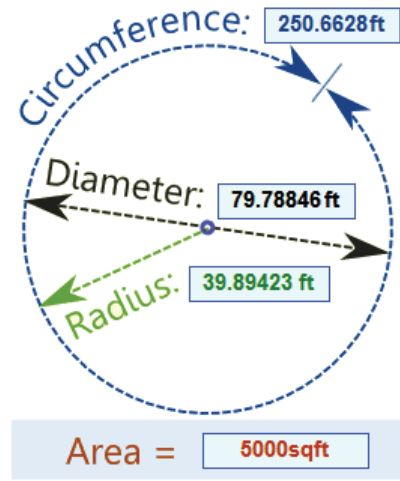

The relative densities of carbon monoxide and nitrogen dioxide compared to air are 0.967 and 1.036 respectively (Air = 1). Carbon monoxide is just slightly lighter than air and nitrogen dioxide is slightly heavier. Both of these gases tend to mix uniformly in the environment depending on air movement within the room or facility. Normally, the unit is mounted about 5 feet (1.5 m) above the floor (in the normal breathing zone), in a central area where air movement is generally good.

Macurco GD-6 for Combustible Gas

These units typically cover about 900 sqft (84 square meters). The radius of coverage is 17 feet (5.2 m) per detector. A GD-6 mounting height is dependent upon the target gas. If the target gas is lighter than air; methane (NG) or Hydrogen (H₂), mount the GD-6 high on a wall or column (about one foot down from the ceiling) in a central area where air movement is generally good. If the target gas is heavier than air, like propane (LP), mount the GD-6 low on a wall or column (about one foot above the floor) in a central area where air movement is generally good.

The detectors must be located as specified by regional building code. Use open interior support columns as much as possible to maximize the radius of coverage, not walls. Each level of the parking structure must be covered without overlapping the coverage of the sensors.

Detection and Ventilation Panel

Usually located out of reach of the general public. Preferably located close to or in the control center or office.



Use open interior support columns as much as possible to maximize the radius of coverage, not walls. Each level of the parking structure must be covered without overlapping the coverage of the sensors.

6. Onboard Diagnostics

Trouble Conditions

Macurco 6-Series Trouble condition

The detector monitors all critical functions of the unit through software diagnostics that continuously test and verify unit operations. If a problem is found, the unit will switch to a fail-safe/error mode or trouble condition.

In this error mode:

- The Alarm relay will be activated
- The unit will display the error code
- The green status indicator LED light will flash
- The buzzer will chirp intermittently
- The 4-20 mA current loop will go to 24 mA

The Fan relay will also engage if the Trouble Fan Setting Option is set to "ON". To clear this mode, simply turn off power to the unit for a few seconds, or push the ENTER/TEST switch (inside the unit). This will cause the unit to restart the 1 minute self-test cycle.



DVP-120 Trouble Status Display

If a sensor fails, a connection is lost or the panel itself detects a failure of its own, the panel will enter TROUBLE mode during which the internal buzzer will sound, the power lamp will be yellow and the LCD will display the specific sensor identified.

Possible trouble conditions are:

1. Any configured channel has less than 4 mA in the current loop
2. A sensor is reporting a trouble condition
3. Any configured channel wiring is open
4. Internal controller board problems are detected

The display will cycle through all trouble indications, at five seconds per display. Pressing any key (except HUSH) will advance the display to the next trouble indicator. If an external horn and/or strobe are connected and configured to signal a trouble condition, they will also sound when a trouble condition occurs, after a delay, if that configuration option is selected.

7. Output signals

Visible, Audible and Mechanical

Macurco 6-Series output options

The detectors have selectable 4-20 mA output, buzzer and digital display options. With the display function turned "On", the detector will show the current concentration of gas or "0" (zero) in clean air. When the gas concentration reaches the Fan Relay setting (35 ppm CO, for example) the display will flash back and forth between "FAn" and "35". With the display function turned "Off", the display does not show the CO concentration, but will show "FAn" as long as the fan relay is activated.

With the display function turned "On" and the CO concentration reaching the Alarm Relay setting, (200 ppm, for example) the display will flash back and forth between "ALr" and "200". The buzzer will sound indicating "Alarm" if the buzzer is turned "On". With the display function turned off the display does not show the CO concentration, but will show "ALr" when the Alarm relay is activated.

With the 4-20 mA function turned "On" and the CO concentration climbing, the 4-20 mA signal will ramp up corresponding to the concentration (0-200 ppm, for example). The display will show "FAn" and "ALr" and sound as outlined above.

DVP-120 Control Panel output options

The DVP-120 has an externally visible LCD display showing the status of each transducer and relay (2 rows of 16 characters with backlight) as well as externally visible system LED alarm and relay status indicators. There is an internal buzzer (90 dBA at 1ft) as well as external horn and strobe drivers (24VDC, max 250 mA).

The DVP-120 can drive the buzzer, horn and strobe with different sound patterns to indicate the severity of the current conditions. These patterns are selectable by the installer using this group of submenus (continuous, intermittent, double tap, etc.)

The DVP-120 control panel provides three relays which can be used for ventilation fan control or alarm signaling. These relays (SPDT - Form C) are for pilot duty only, capable of switching 10 amp loads up to 240 VAC. The relay operation can be configured as Normally Off or On, with Delay Time and Minimum Runtime.



Configuration menus define the output of the Alarm, Warning and Trouble Signals (Buzzer, Horn and Strobe) as On, Off, Intermittent, Continuous, etc. When a zone is controlling the horn or strobe and they are activated, the panel will enter ZONE SIGNAL mode during which the horn and/or strobe will be turned on and the LCD will show the zone that is signaling.

The HUSH key is only used to silence the audible indicators (internal buzzer and external Horn and Strobe devices). Pressing and releasing the Hush button will silence the internal buzzer while pressing and holding the button for three seconds will silence the Horn and Strobe.

8. Closeout

Demonstration and Training

Inspect the components, equipment installation and electrical connections for compliance with requirements. Test the alarm set points of the gas detection system with calibration and test gases and verify sequence of operation.

Perform demonstrations and train maintenance personnel to adjust, operate, trouble-shoot, calibrate and maintain the gas detection and ventilation control systems. Calibration and test kits should be provided with the gas detection system. Calibration and test intervals must comply with manufacturer's recommendations.

If required, prepare a written report to record test procedures, test results and corrective actions. The report should also cover the requirements for accessories like acceptability of alarm types, signs and protective equipment. Any repair or replacement of malfunctioning units should be performed by Macurco.



Celebrating over 40 years of gas detection, the Macurco product line offers fixed gas detection equipment for residential, commercial and industrial applications. Since 1972 Macurco has been providing gas detection options for a number of different gases including carbon monoxide (CO), nitrogen dioxide (NO₂), hydrogen (H₂), propane (LP) and methane (natural gas). The Macurco product line features UL, ETL, LADBS and CSFM approved products. Headquartered in Sioux Falls, South Dakota, Aerionics, Inc. manufactures the Macurco fixed gas detection product line. Aerionics strives to provide the highest quality gas detection, safety and security solutions to customers worldwide. Whether you are looking for a gas detector for your security system, building automation or HVAC system, Macurco has a gas detector to meet your needs.

Products for Ventilation Control and for use with HVAC Systems

Macurco commercial products are designed to meet OSHA and IBC standards as well as other local codes for Carbon Monoxide (CO), Combustible Gases and other Toxic Gas detection. The Macurco 6-Series and 12-Series detectors can be used stand-alone or can be integrated with the Macurco DVP-120 Control Panel or HVAC and Fire/Security Systems. For use in Parking Garages, Warehouses and other Commercial Buildings, these products are all ETL Listed. The DVP-120 and the CM-6 are also LADBS Approved for use in Los Angeles, CA.

DVP-120 & DVP-120M Detection and Ventilation Panels



Provides automatic control, when used with Macurco transducers, to help maintain acceptable levels of various gases in parking garages, warehouses and other commercial facilities – ETL Listed, LADBS Approved

- 90 to 250 VAC power input
- Three 10A SPDT Fan / Alarm Relays
- Two 24 VDC drivers for Horn & Strobe
- External display show system and sensor status
- Both models offer 12 analog (4-20mA) inputs.
- DVP-120M adds 87 digital (RS-485) inputs for a maximum of 99 detectors.



Macurco 6-Series and 12-Series Detector, Controller and Transducers



The Macurco 6-Series and 12-Series detectors provide automatic control to help maintain acceptable levels of CO, Combustible Gases or Toxic Gases in parking garages, warehouses and other facilities - Can be used as stand-alone detectors and controllers and as analog transducers for use with the Macurco DVP-120 and other systems – ETL Listed

6-Series (12-24 VAC or 12-32 VDC input) & 12-Series (100-240 VAC input)

- 5A SPDT Fan control relay
- 0.5A N.O. or N.C. Alarm Relay
- Selectable Fan and Alarm Relay Actuation Settings
- Digital Display, Internal Buzzer



Carbon Monoxide CM-6 and CM-12

Combustible Gases GD-6 and GD-12

Toxic Gases TX-ND for NO₂, TX-HS for H₂S, TX-AM for NH₃

Specialty Gases RD for Refrigerants, OX for O₂, CD for CO₂

Macurco Addressable Gas Detection and Control



The Macurco MRS-485 Modbus RS-485 adapter is intended for use with Macurco 6-Series detectors. Devices can be tied into multipoint addressable systems and the Macurco DVP-120M Modbus Enabled Detection and Ventilation Control Panel. The DVP-120M holds up to 87 Modbus addressable sensors on three channels of 29 sensors per channel, plus the original 12 analog 4-20mA sensor channels.

MACURCO

GAS DETECTION



Made in the USA

Celebrating over 45 years of gas detection, the Macurco product line offers equipment for residential, commercial and industrial applications. Since 1972 Macurco has been providing detection options for a number of different gases including carbon monoxide (CO), nitrogen dioxide (NO₂), hydrogen (H₂), propane (LP), methane (natural gas), hydrogen sulfide (H₂S), ammonia (NH₃), oxygen (O₂), carbon dioxide (CO₂) and refrigerants. Headquartered in Sioux Falls, South Dakota, Aerionics manufactures Macurco Gas Detection products. Aerionics strives to provide the highest quality detection, safety and security solutions to customers worldwide. Whether you are looking for gas detection for a security system, building automation or HVAC system, for personal safety or for monitoring specific gases in potentially hazardous environments, Macurco has a gas detector to meet your needs.

Visit www.macurco.com for additional product information and training



www.facebook.com/macurcogasdetection



www.linkedin.com/company/macurco-gas-detection